

Techsense Bangladesh Ltd

Photoelectric Proximity Switch, Code : PSF-DM2DPB

A Photoelectric Sensor consists primarily of an Emitter for emitting light and a Receiver for receiving light. When emitted light is interrupted or reflected by the sensing object, it changes the amount of light that arrives at the Receiver. The Receiver detects this change and converts it to an electrical output. These sensors are made of light sensitive parts. This makes them useful in detecting the light emitters or any type of light source. There are various types of this sensor. Majorly they utilize the phenomena of reflection of light in which emitter and receiver together detect the reflection of light that strikes the object. In some other cases they spot any disturbance due to the target in the beam of light.

General Attributes

- Housing size : 32*21*12.1
- Mode : Retro reflection
- SN : 2m
- Light source : Infrared LED (880nm)
- Output : PNP NO
- Power supply : 12...24VDC
- Response time : Max, 1ms
- Repeat accuracy : ≤5%
- Load current [mA] : ≤100mA
- Residual voltage : ≤2.5V
- Consumption current : ≤25mA
- Protection circuit : Surge and reverse polarity
- Indicator : Yellow LED
- Ambient temp : -15...55°C
- Ambient RH : 35-95%
- Protection degree : IP67
- Housing material : ABS/PC
- Connection : Cable

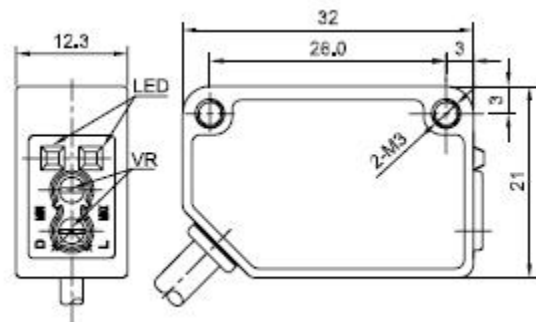

Dimension Drawing

Application Notes

- Checking presence, inspecting completeness, counting and sorting.
- Checking the presence of coloured objects, detection of printed marks, inspecting LEDs, colours and luminescent objects
- Measurement of parts, monitoring of sag, measurement of thickness and distance, measurement of path and filling level.
- Reading of bar codes and data matrix codes, OCR, tracking of components, colour identification.
- Front-edge detection, Pick & Place, quality inspection

For further information please visit : <https://goo.gl/zUkQYk>

